



5@< 'GMGH9A G'@H8

5@< 'GMGH9A '%
CD9F 5H=B; 'A 5BI 5@

7CBH9BHG

CD9F 5HB; '5B8'G9F J =79'BC H9G	D5; 9%
5@< 'GMGH9A '%DF C8I 7H'F 5B; 9	D5; 9&
5@< 'GMGH9A '%G9F J =79'J 5@ 9'D5F HG '@GH'	D5; 9'
5@< 'GMGH9A '%G9F J =79'J 5@ 9'9LD@C898'8-5; F 5A '	D5; 9(
5@< 'GMGH9A '%8F @@B; 'A 57 < =B9'9LD@C898'8-5; F 5A ' / 'D5F HG '@GH	D5; 9)
5@< 'GMGH9A '% '!%&'65; HI 69'9LD@C898'8-5; F 5A ' / 'D5F HG '@GH	D5; 9*
5@< 'GMGH9A '%D@ ; 'BG9F H€B'9LD@C898'8-5; F 5A	D5; 9+
5@< 'GMGH9A '%6MD5GG'9LD@C898'8-5; F 5A	D5; 9,
5@< 'GMGH9A '%D9'585DH9F'9LD@C898'8-5; F 5A '	D5; 9-
5@< 'GMGH9A '%DI F; 9'9>97HCF'9LD@C898'8-5; F 5A	D5; 9%\$
5@< 'GMGH9A '%8F @@B; '5B8'H5DD-B; 'DF C798I F 9	D5; 9%%
5@< 'GMGH9A '%65; ; =B; 'C.: 'DF C798I F 9	D5; 9%*



5@< 'GMGH9A G'@A #H98
%? =B; 8CA '5J 9BI 9
BCFH<57F9' =B8I GHF -5@D5F?
K 9GH6I FMZK @HG"65% (K 9
H9@ ÉI I A G D A F I H A I I G H
9!A 5=@ gU'Yg4 U\!gmY a g"Vt"i _

CD9F 5H-B; '5B8 'G9F J =7 9 'BCH9G

H<9'5@<'GMGH9A '%G9FJ =79'J5@9'5B8'H<9'5@<'GMGH9A '%8F @G9H'5F9'89G= B98'K #<'95G9 C: 'I G9'5B8 '@CK 'A 5-BH9B5B79'5'DF €CF #M'

BC'D@5BB98'A 5-BH9B5B79'DFC; F5A '€F9EI ≠98 HC'?'99D'H<9?'#B':I '@@K CF?'B; 'CF89F"

5'J €I 5@-BGD97H€B'B7@ 8-B; '7CB8#€B'C: G95@G'G<CI @8'69'7CAD@9H98'69: CF9'957< CD9F5H€B"5: H9F'957<'I G9'H<9?'#G<CI @8 69'7@95B98'HC'F9ACJ9'5BM: CF9= B'A5H9F-5@ K <=7<'7CI @8'AD5F':I HI F9'I G9'C: 'H<9?'#"

H<€'8C7I A9BH'HC'69'F958'B'7CB>I 7H€B K #<'7I FF9BH'B8I GHF M7C89G'C: 'DF57H=79



5@<'GMGH9A G'@A #H98
%?'B; 8CA '5J9BI 9
BCFH<57F9'B8I GHF-5@D5F?
K 9GH6I FMZK €HG"65% (K 9

H9@ ÉI I A G D A H I H A I I G H

9!A 5=@ gU'Yg4 U\!gmYg g"Vt"i _

5@ 'GMGH9A '%DF C 8I 7H'F 5B; 9

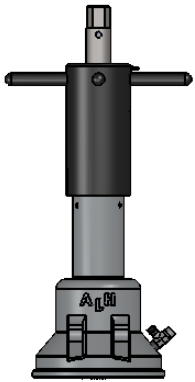

5@ 'GMGH9A '%
8F @@B; 'A 57< B9

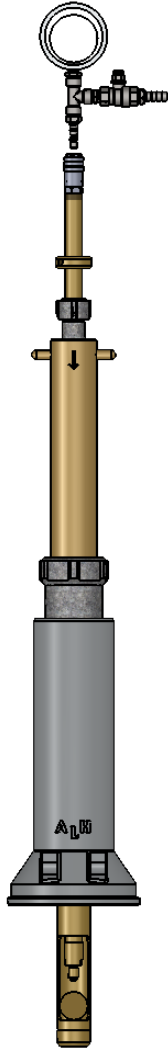

5@ 'GMGH9A '%
65; HI 69

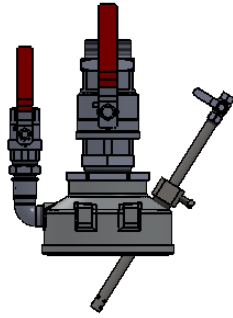

5@ 'GMGH9A '%
6MD5GG

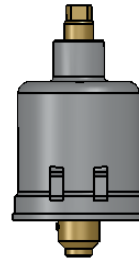

5@ 'GMGH9A '%
D@ ; 'BG9F HCB

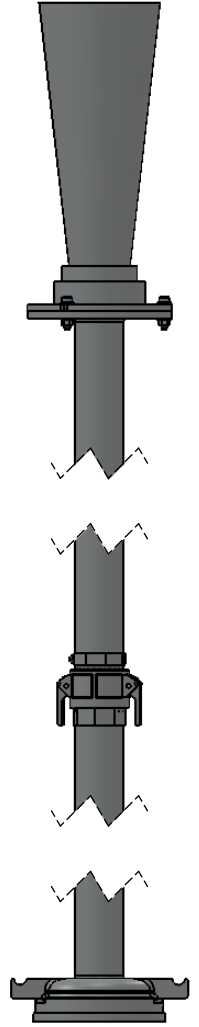

5@ 'GMGH9A '%
DI F; 9 9>97HCF

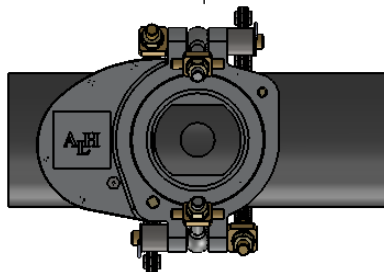

5@ 'GMGH9A '%G9F J 79 J 5@J 9



5@ 'GMGH9A '%
D9'585DH9F



5@ 'GMGH9A G'@A #98
%? B; 8CA '5J 9BI 9
BCF H<57F 9' B8I GHF -5@D5F?
K 9GH6I FMZK @HG"65% (K 9

H9@ ÉI A G D A H A I I G H

9!A 5@ gUYg4 U\!gmY a g"Vt"i _

5@< 'GMGH9A '%G9F J =7 9' J 5@J 9
5\$\$\$&\$

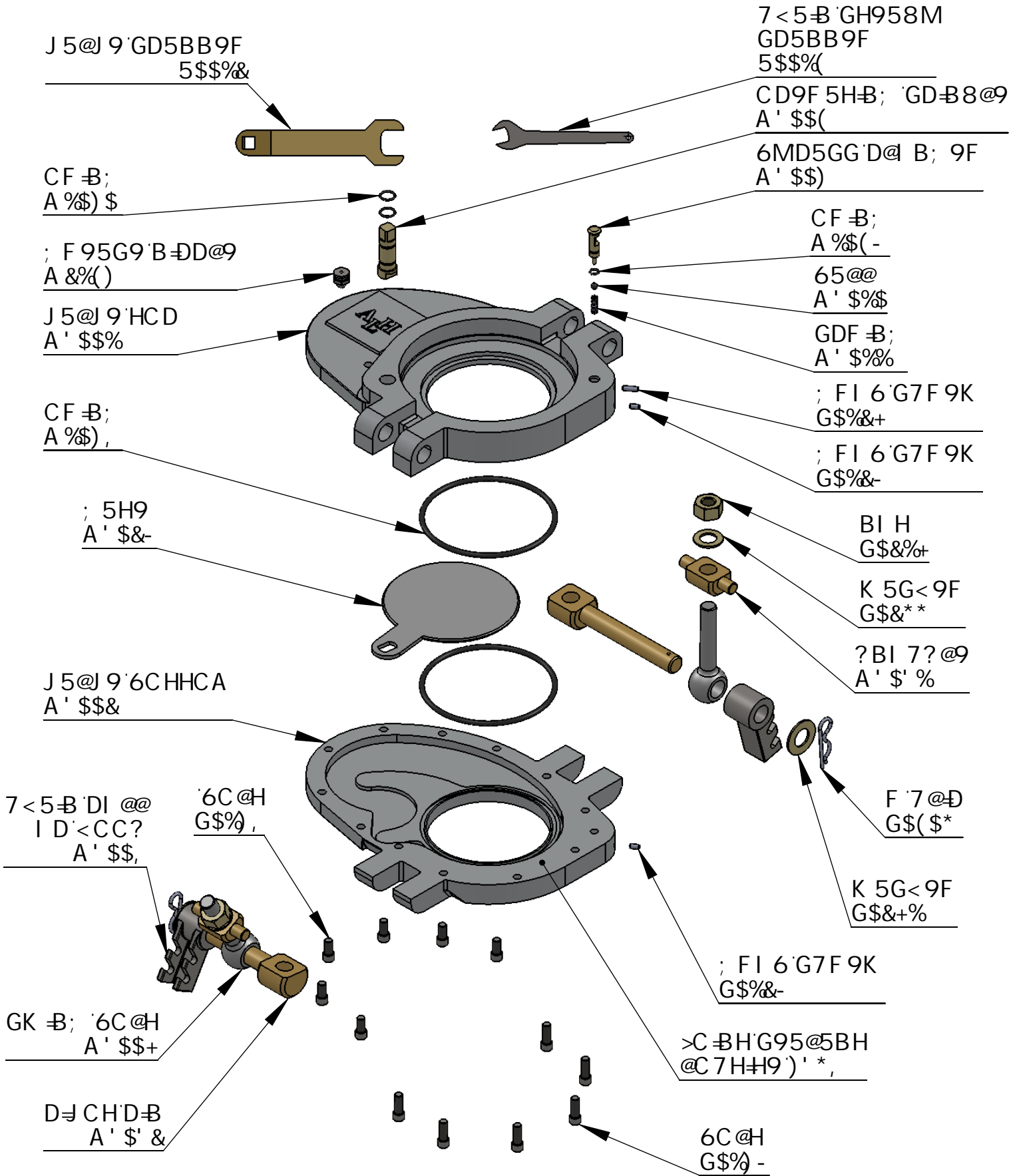

5@< 'GMGH9A G'@A #98
%? -B; 8CA '5J 9BI 9
BCFH<57F 9'-B8I GHF -5@D5F?
K 9GH6I FM'K @HG''65% (K 9

H9@ ÉI I G D A H A I I G H

9!A 5@ gUYg4 U\!gmY a g"Vt"i _

D5; 9'(<

5@< 'GMGH9A '%8F @@B; 'A 57 < B9

5() \$\$

: 998 '<5B8@9G
A &%t'

G<5: H'@C7? B;
G7F 9K
A (%)

: 998 '75D
A &%t&

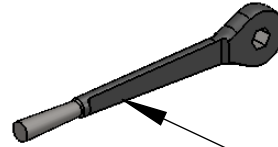

F 5H7 < 9H
A (%* &

CF B;
A %\$&&

H<F I GHF 579
A (%&&

8F @@65G9
A &%t\$



5@@9B '8F J 9F
5\$\$%t

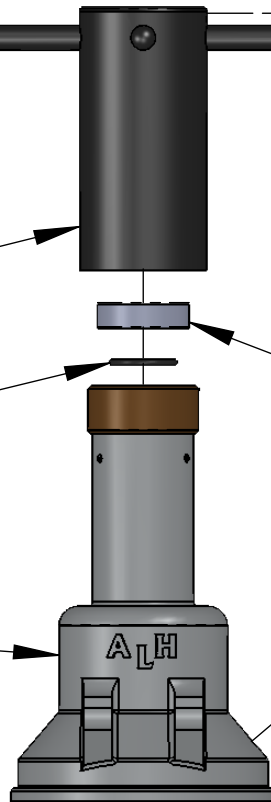

65@@J 5@J 9
A '\$-

CF B;
A %\$) *

G<5: H
F 9H5 B B; 'D B
A &%t(

6GD 'H5D	D5F H'BC"
' # "	5\$&* \$
%"	5\$&* %
%%# "	5\$&* &
%%#&"	5\$&* '
&"	5\$&* (
&'%#&"	5\$&+ \$

8F @@G<5: H
A &%* -

6GD '<C@9G5K	D5F H'BC"
H D Ä G { { D	5\$&*)
F Ä C H { { D	5\$&* *
F Ä D Ä C H { { D	5\$&* +
F Ä D Ä C H { { D	5\$&* ,
G Ä C { { { D	5\$&* -
G Ä D Ä C H { { D	5\$&+ ,

; F I 6 'G7F 9K
G\$%* *

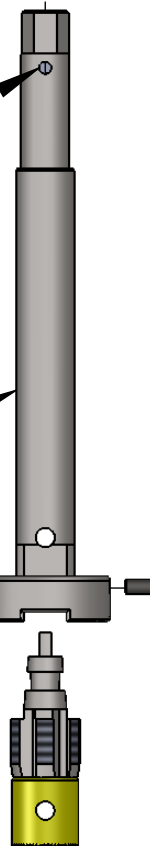

5@< 'GMGH9A G'@A #98
%? B; 8CA '5J 9BI 9
BCFH<57F 9' B8I GHF -5@D5F?
K 9GH6I FM'K @HG"65% (K 9

H9@ É I Ä G Ä H Ä I G H

9!A 5 @ gU'Yg4 U\!gmY'a g'Vt'i _

D5; 9)

5@ 'GMGH9A '% !%&'65; HI 69
 %&!- \$\$\$

65; 'HMD9	D5F H'BI A 69F
' " ; €!9(: @CK GHCD'65;	5\$%&%
(" ; €!9(: @CK GHCD'65;	5\$%&&
* " ; €!9(: @CK GHCD'65;	5\$%&(
, " ; €!9(: @CK GHCD'65;	5\$%&*
%\$ " ; €!9(: @CK GHCD'65;	5\$%&,
%& " ; €!9(: @CK GHCD'65;	5\$%&-

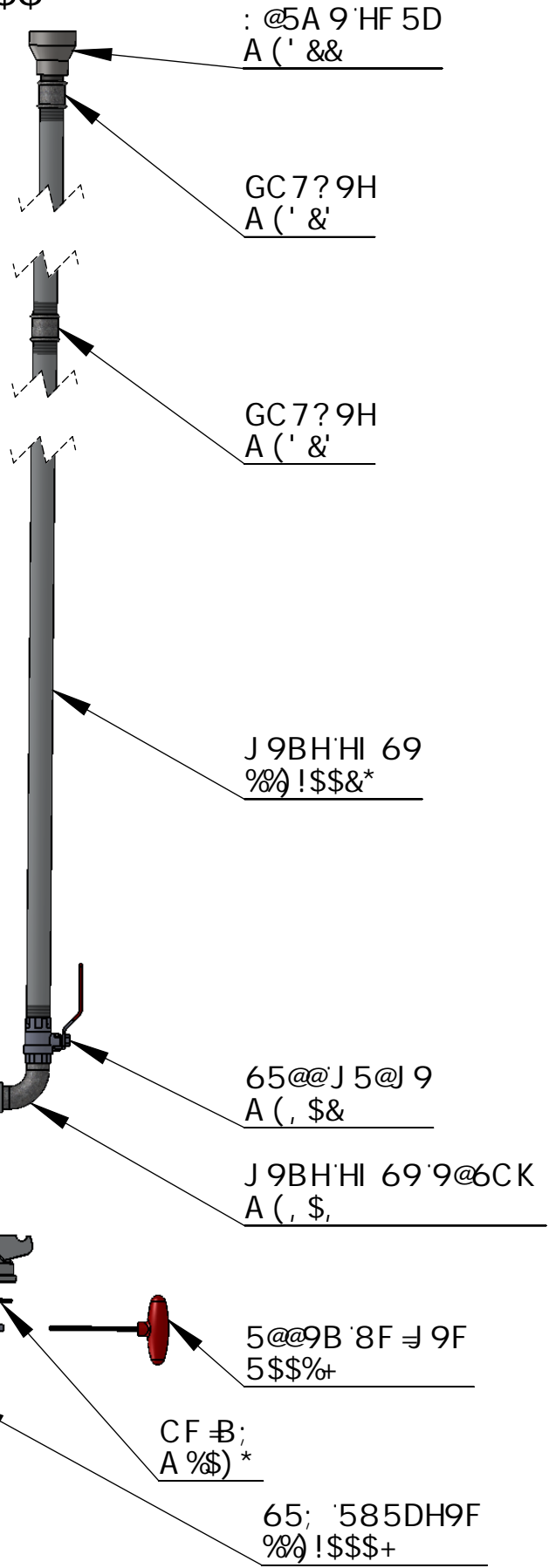

⊖: @5H€B'7CBHFC@
 %&!\$\$\$%

⊖: @5H€B'HI 69
 %&!\$\$\$*

; | ⊖9'7C@5F
 %&!\$\$\$,

65; HI 69
 %&!\$\$\$&

75BCDM
 %&!\$\$\$%

; FI 6'G7F9K
 G\$%*+

'!("'G<C9
 %&!\$\$\$)

*!, "'G<C9
 %&!\$\$\$(<

%\$!%&'G<C9
 %&!\$\$\$'

: @5A 9'HF 5D
 A (' &&

GC7?9H
 A (' &

GC7?9H
 A (' &

J9BH'HI 69
 %&!\$\$\$*

65@J 5@J 9
 A (, \$&

J9BH'HI 69'9@6CK
 A (, \$,

5@9B'8F ⊖ 9F
 5\$\$\$+

CF ⊖;
 A %\$)*

65; '585DH9F
 %&!\$\$\$+



5@ 'GMGH9A G'@A #98
 %? ⊖; 8CA '5J9BI 9
 BCFH<57F9'⊖8I GHF -5@D5F?
 K 9GH6I FM'K ⊖HG''65% (K 9

H9@ ÉI | A€D€H HÁI ìGH

9!A 5@ gU'Yg4 U\!gmYg g"Vt"i _

5@< 'GMGH9A '%D@ ; 'BG9F H€B

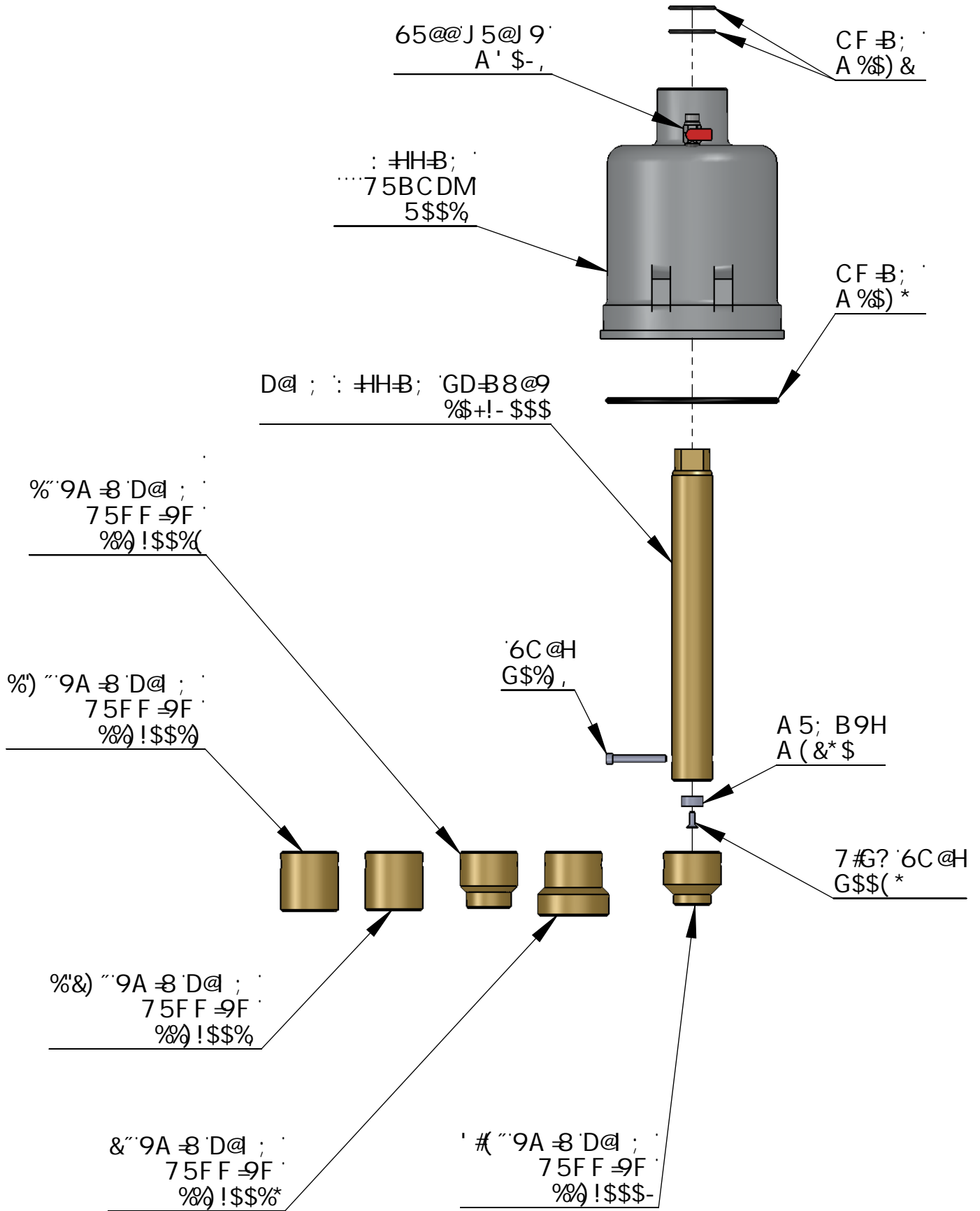

5@< 'GMGH9A G'@A #H98
 %? ß; 8CA '5J9BI 9
 BCFH<57F9' -B8I GHF -5@D5F?
 K 9GH6I FMZK -@HG''65% (K 9

H9@ ÉI A€DA HÁIIGH

9!A 5-@ gUYg4 U\!gmY'a g'Vt'i _

5@ 'GMGH9A '%6MD5GG %&!- \$\$%

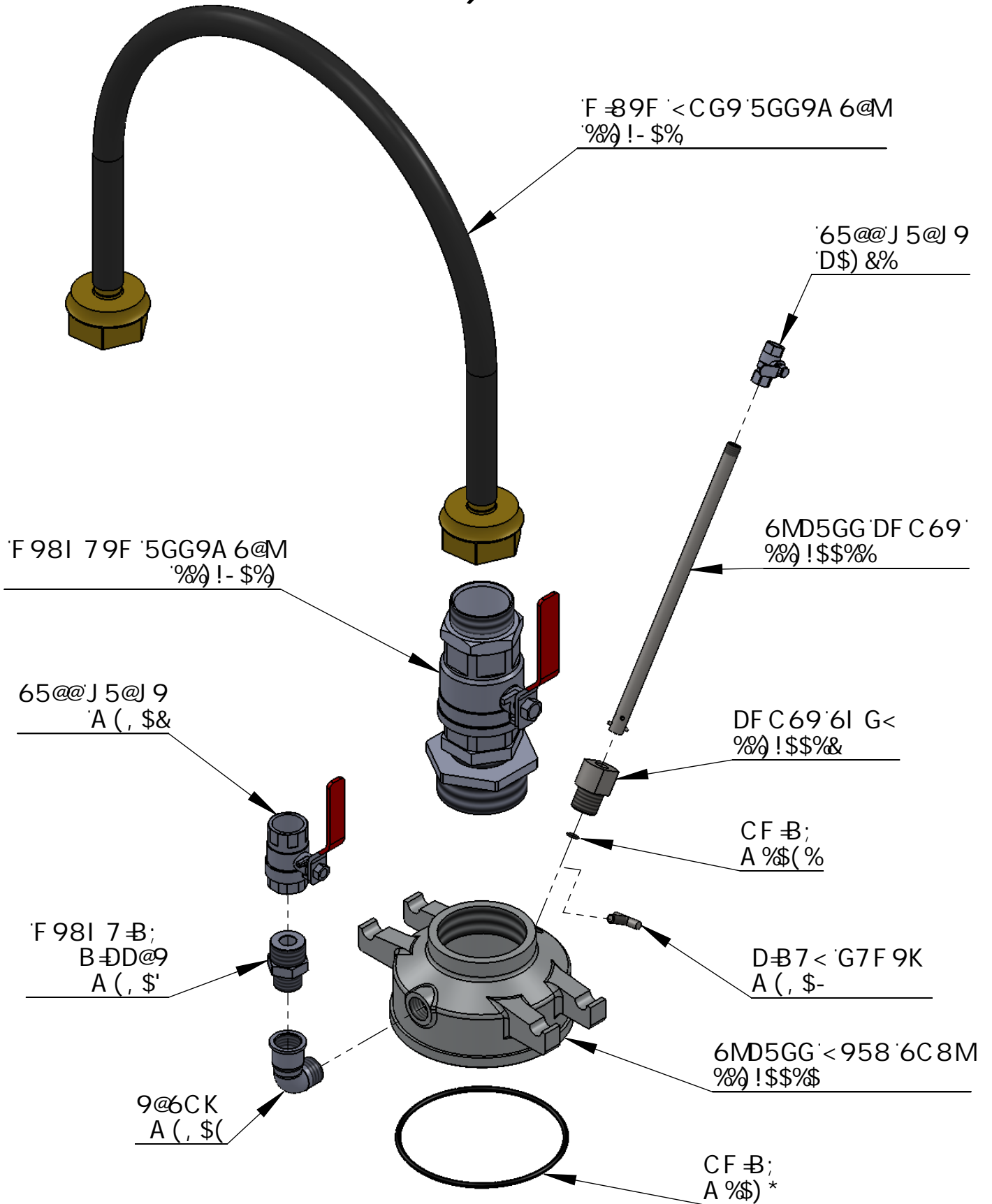

5@ 'GMGH9A G'@A #H98
%? B; 8CA '5J 9BI 9
BCFH<57F 9' B8I GHF -5@D5F?
K 9GH6I FMZK @HG"65% (K 9

H9@ ÉI I A G D A H A I I G H

9!A 5@ gUYg4 U"!gmY a g"Vt"i _

5@< 'GMGH9A '%D9'585DH9F '5GG9A 6@M
 %/%) !- \$%*

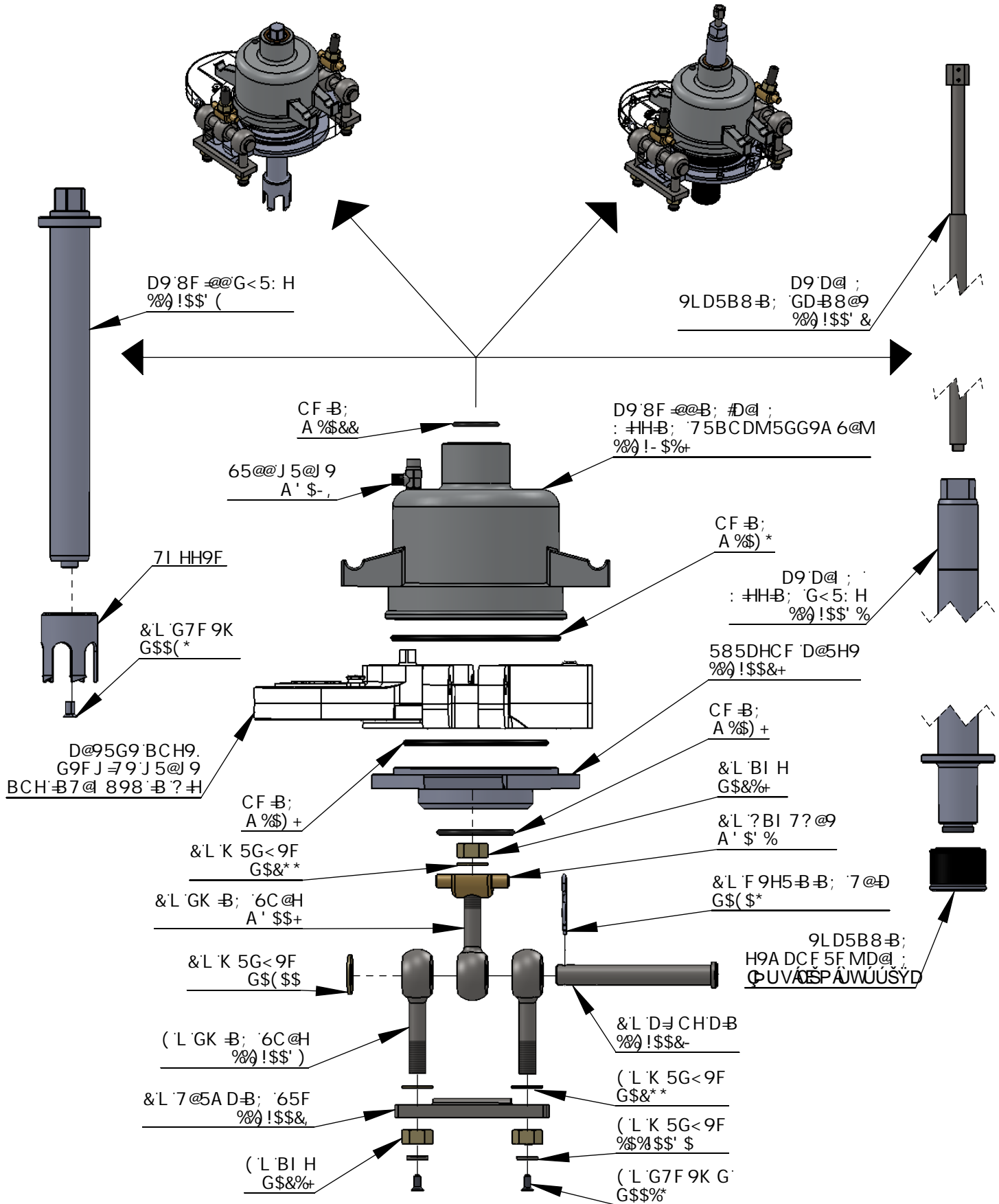

5@< 'GMGH9A G'@A #H98
 %? -B; 8CA '5J 9BI 9
 BCF H<57F 9'-B8I GHF -5@D5F?
 K 9GH6I FM'K @HG"65% (K 9

H9@ É I I A G D A H A I I G H

9!A 5@ gU'Yg4 U'!gmY'a g"Vt'i _

5@< 'GMGH9A '%DI F; 9'9>97 HCF %/%) !- \$&\$

J 9BHI F =GHM@9
6@CK 9F
'%/%) !\$\$()

' 'L '6C@HG
G\$' , ,

* 'K 5G<9FG
G\$&''*

' 'BI HG
G\$&%+'

K 9@898 '5@ A -B+ A 'HI 69
/ : @5B; 9'G97H-CB
%/%) !\$\$('

A 5@9'7CI D@B; '
A (*%/%

: 9A 5@9'7CI D@B; '
A (*%&

K 9@898 '5@ A -B+ A 'HI 69
/ '6CF 98 'B+ <H'75D'G97H-CB
%/%) !\$\$('



5@< 'GMGH9A G '@A #H98
%? -B; 8CA '5J 9BI 9
BCFH<57F 9'-B8I GHF -5@D5F?
K 9GH6I FMZK -HG''65% (K 9

H9@ ÉI | ÁGDAFI HÁI ïGH

9!A 5=@ gUYg4 U\!gmY a g"Vt"i _

5@< 'GMGH9A '%8F =@@B; '5B8 'H5DD-B; 'DF C798I F 9

GH9D %

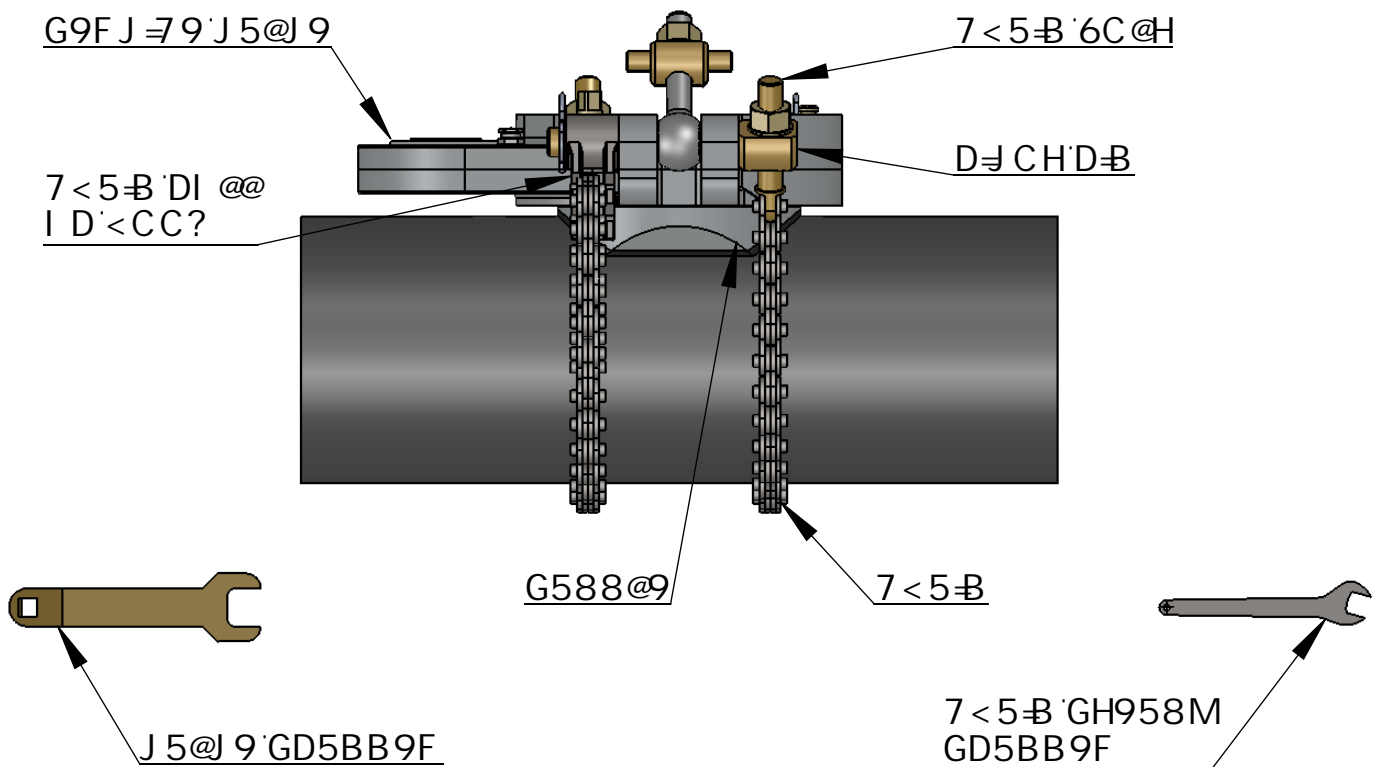

%' 7 @95B 'HCD'C: 'D-D9

&' D@579 '5DDF CDF =5H9 'G-N9 G588 @9 'CB 'D-D9

' " : #'G9F J 79 J 5 @ 9 'CBHC 'G588 @9

(" DI G < '7 < 5-B '6C @HG 'H < F CI ; < 'D=J CH'D-BG 5B8 'G97I F 9 'K #' < 'K 5G < 9F '5B8 '7 < 5-B BI H

)" D5GG '7 < 5-BG 'I B89F 'D-D9 '5B8 : #'-BHC 7 < 5-B 'DI @@ I D' < CC?

*" GI DDCF H'7 < 5-B 'K #' < '7 < 5-B 'GH958M GD5BB9F '5B8 'H= < H9B '7 < 5-B 'BI H' K #' < 'J 5 @ 9 'GD5BB9F †

† #'-G '9GG9BH-5@H < 9 '5@< 'J 5 @ 9 'GD5BB9F -G 'I G98 'B 'CF 89F 'HC 'F 98I 79 'H < 9 'F -G? C: 'CJ 9F 'H= < H9B-B; 'H < 9 '7 < 5-B '6C @HG



5@< 'GMGH9A G'@A #98
 %? -B; 8CA '5J 9BI 9
 BCF H<57F 9'-B8I GHF -5@D5F?
 K 9GH6I FM'K -HG''65% (K 9
 H9@ É I A G D A H A I I G H
 9!A 5@ gU'Yg4 U'\!gmY a g"Vt"i _

GH9D &

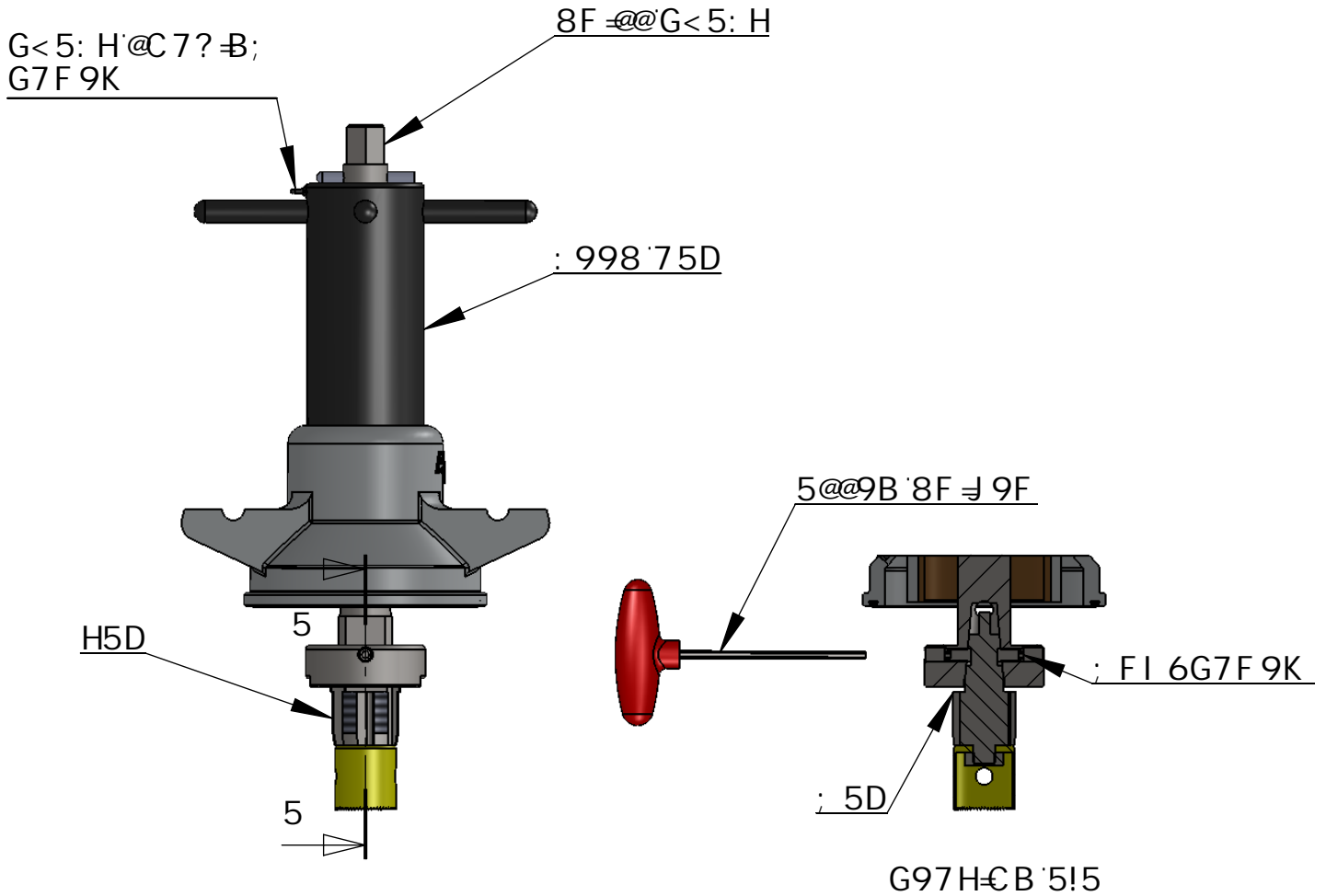

- % K -B8 : 998 75D 8CK B HC GHCD
- & F 9@95G9 G<5: H'@C7? -B; G7F 9K
5B8 5@@CK 8F @@G<5: H'HC 8F CD
- ' " F 9A C J 9 ; FI 6G7F 9K G
- (" : #7CFF 97H H5D 5B8 H ∽ < H9B
; FI 6G7F 9K G

HC F 9@95G9 H5D -BG9F H
G7F 9K 8F ∽ 9F -BHC ; 5D G<CK B



5@ GMGH9A G @A #H98
%? -B; 8CA 5J 9BI 9
BCFH<57F 9 -B8I GHF -5@D5F?
K 9GH6I FMZK -HG"65% (K 9
H9@ ÉI A G D A H A I I G H
9!A 5 @ gUYg4 U \!gmY a g"Vt"i _

GH9D''

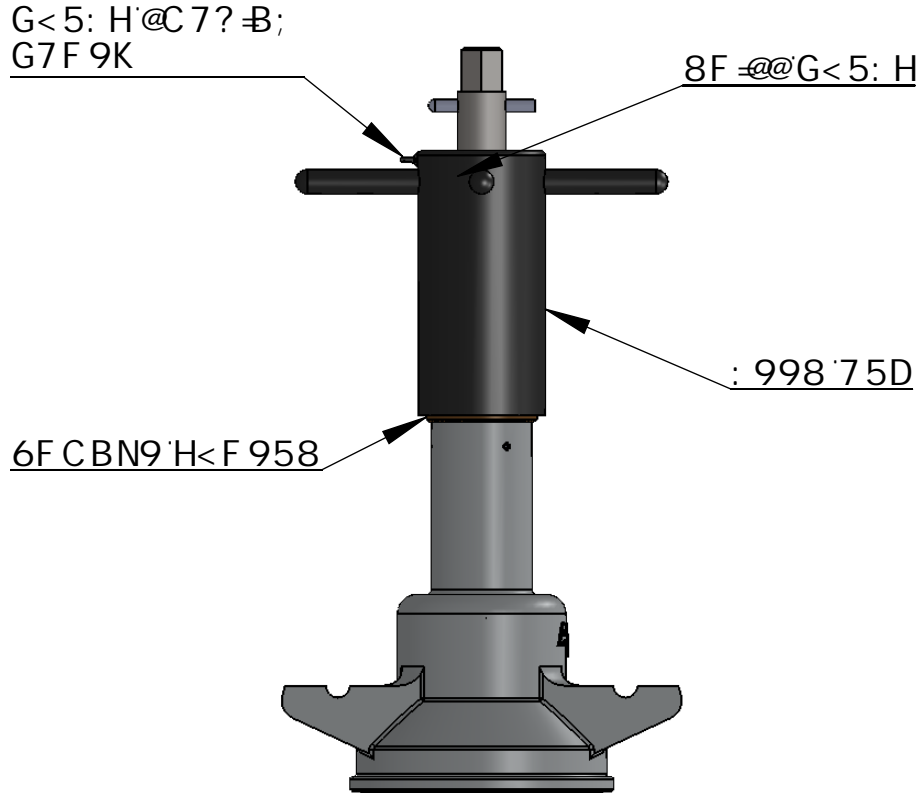

% K B8 : 998 75D I D I BH @ 6F CBN9 H<F 958
G J G 6 @ 9

&" G@C K @MF CH5H9 8F @@G<5: H I BH @ H 75B
69 F 5 G98 I D H< G 5 @ 7 BG H< 9 GE I 5F 9 CB
H< 9 8F @@G<5: H K H< H< 9 GE I 5F 9 B H< 9
8F @@65G9 K < 7 < DF 9J 9BHG H< 9 ; 5H9
69 B ; 8F @@98

' " H 7 < H9B G<5: H'@C7? B; G7F 9K



5@ GMGH9A G @A H98
%? B; 8CA 5J 9BI 9
BCFH<57F 9 B8I GHF 5@D5F?
K 9GH6I FMZK @HG"65% (K 9

H9@ É I A G D A H I H A I I G H

9!A 5 @ gUYg4 U \!gmY a g"Vt"i _

GH9D`(`

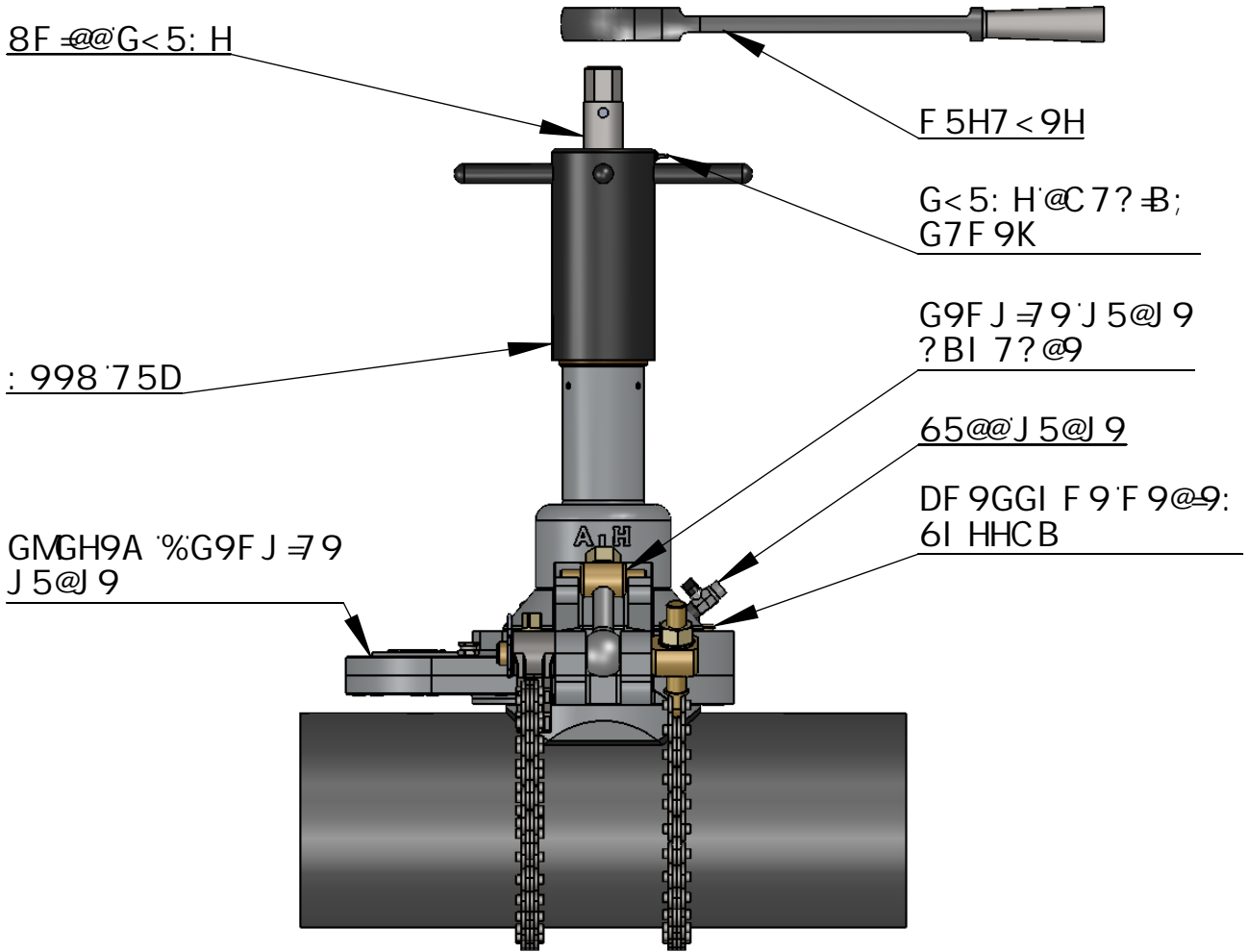

- % A CI BH'8F @@B; A 57<B9'CBHC GMGH9A %G9F J 79 J 5@ 9
- & G97I F 9'I G-B; G9F J 79 J 5@ 9 ?BI 7? @9 5B8'H< <H9B BI HG
- ' " DF 9GGI F 9'H9GH'J 5@ 9'I G-B; 8F @@B; A 57<B9'65@@J 5@ 9
- (" DF 9GG'DF 9GGI F 9'F 9@9: 6I HHCB HC'9E I 5@G9'DF 9GGI F 9
-)" CD9B GMGH9A %J 5@ 9
- *" @CCG9B G<5: H'@C7? B; G7F 9K
- + " K B8'8CK B : 998 75D'I BH@H<9'7I HH9F 'F 957<9G'H<9'DD9
- , " F CH5H9'H<9'8F @@G<5: H'I G-B; F 5H7<9H'CF BI H'FI BB9F
- " K B8'8CK B'H<9: 998 75D'6M5DD@MB; ; 9BH@9'DF 9GGI F 9



5@ GMGH9A G'A H98
 %? B; 8CA 5J 9BI 9
 BCF H<57F 9'B8I GHF 5@D5F?
 K 9GH6I FMZK @HG"65% (K 9

H9@ ÉI A G D A H A I I G H

9!A 5@ gU'Yg4 U\!gmY'a g"Vt"i _

GH9D)

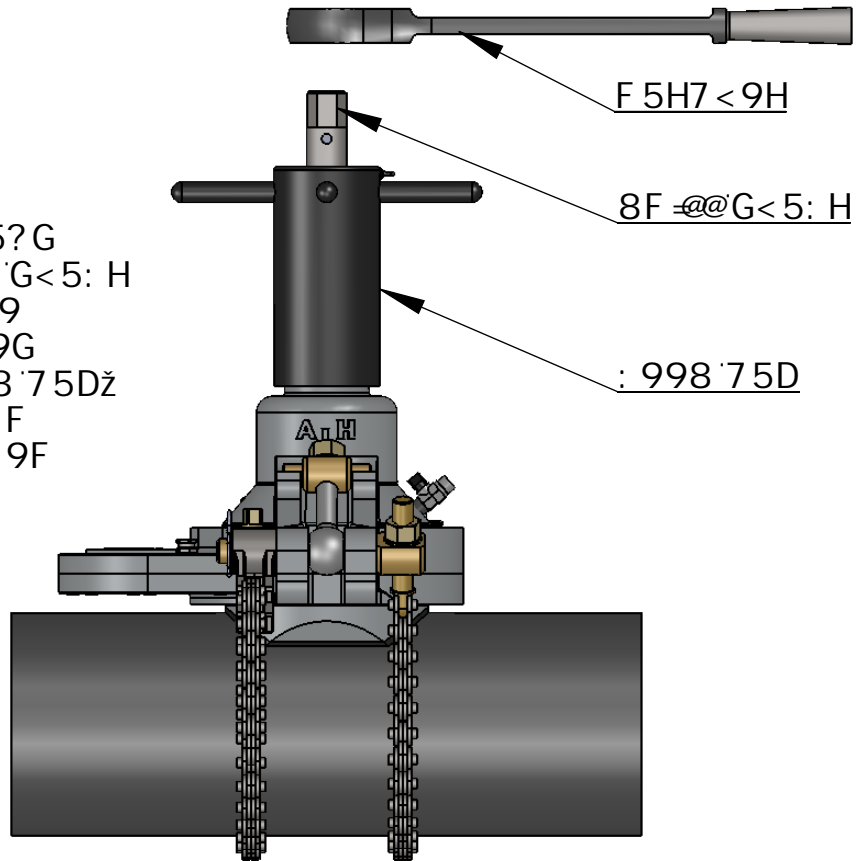

K < 9B 7I HH9F 6F 95?G
 H<FCI ; < DĐ9ŽH<9'G<5: H
 A 5M8F CD'I BH@H<9
 F 9H5-B-B; D-B A 5?9G
 7CBH57H'K #k: 998 75Dž
 H<G A 5MBCH'C77I F
 CB'DĐ9G'K #k < ÷ < 9F
 ; 5G'DF 9GGI F 9

- % K B8 8CK B: 998 75D'I BH@F 9G-GH5B79'G: 9@H
- & F CH5H9 8F @@G<5: H'I G-B; F 5H7 < 9H'HC
9B; 5; 9 H5D
- ' " 7CBH-BI 9'HC F CH5H9 8F @@G<5: H'HC H5D'<C@9
- (" #H'G'CB@MB979GG5F MHC K B8: 998 75D': I FH<9F
HC A 5-BH5-B; 5D'69HK 99B F 9H5-B-B; D-B 5B8
: 998 75D
-)" CB79 H5D'G F CH5H-B; : F 99@M H5DD-B; G 7CAD@9H9
- *" F 9J 9F G9'H<9 8F @@G<5: H'HC I BK B8'H<9 H5Dž#A 5M
69'B979GG5F MHC 5@GC I BK B8'H<9: 998 75D
- + " F 9: 9F '657? 'HC 'GH9D" 'HC F 5-G9 7I HH9F
- , " 7@CG9 GMGH9A %J 5@J 9
- " J 9BH'5B8 F 9A CJ 9 8F @@B; A 57 < -B9



5@ GMGH9A G'A H98
 %? B; 8CA 5J 9BI 9
 BCF H<57F 9-B8I GHF 5@D5F?
 K 9GH6I FMZK @HG"65% (K 9
 H9@ ÉI I G D A H A I I G H
 9!A 5@ gUYg4 U\!gmY a g"Vt"i _

5@< 'GMGH9A '%65; ; ß; 'C: : 'DF C798I F 9

GH9D '%

: CF 'D=Ð9G' ß 'H<9' F 5B; 9' '!'&"

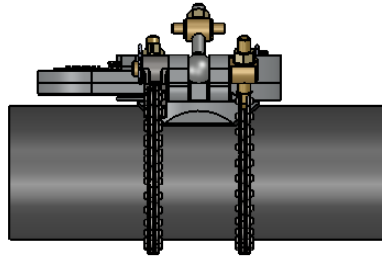

8F =@@5B8 'H5D'D=Ð9'577CF 8 ß;
HC 'H<9'5@< 'GMGH9A '%8F =@@ß; / 'H5DD ß;
DF C798I F 9'HC 'H<9: C@@CK ß; '
G=Ñ9G.

%''6GD'CB' '!("'D=Ð9
%%&"6GD'CB '*"'!; "'D=Ð9
&"6GD'CB '%\$"'!%&"D=Ð9



5@< 'GMGH9A G'@A #H98
%? ß; 8CA '5J 9BI 9
BCF H<57F 9' ß8I GHF =5@D5F?
K 9GH6I F M'K =HG''65% '(K 9

H9@ É I Á G D Á H Á I Ì G H

9!A 5=@ gUYg4 U\!gmYg g"Vt"i _

D5; 9 '%*

GH9D &

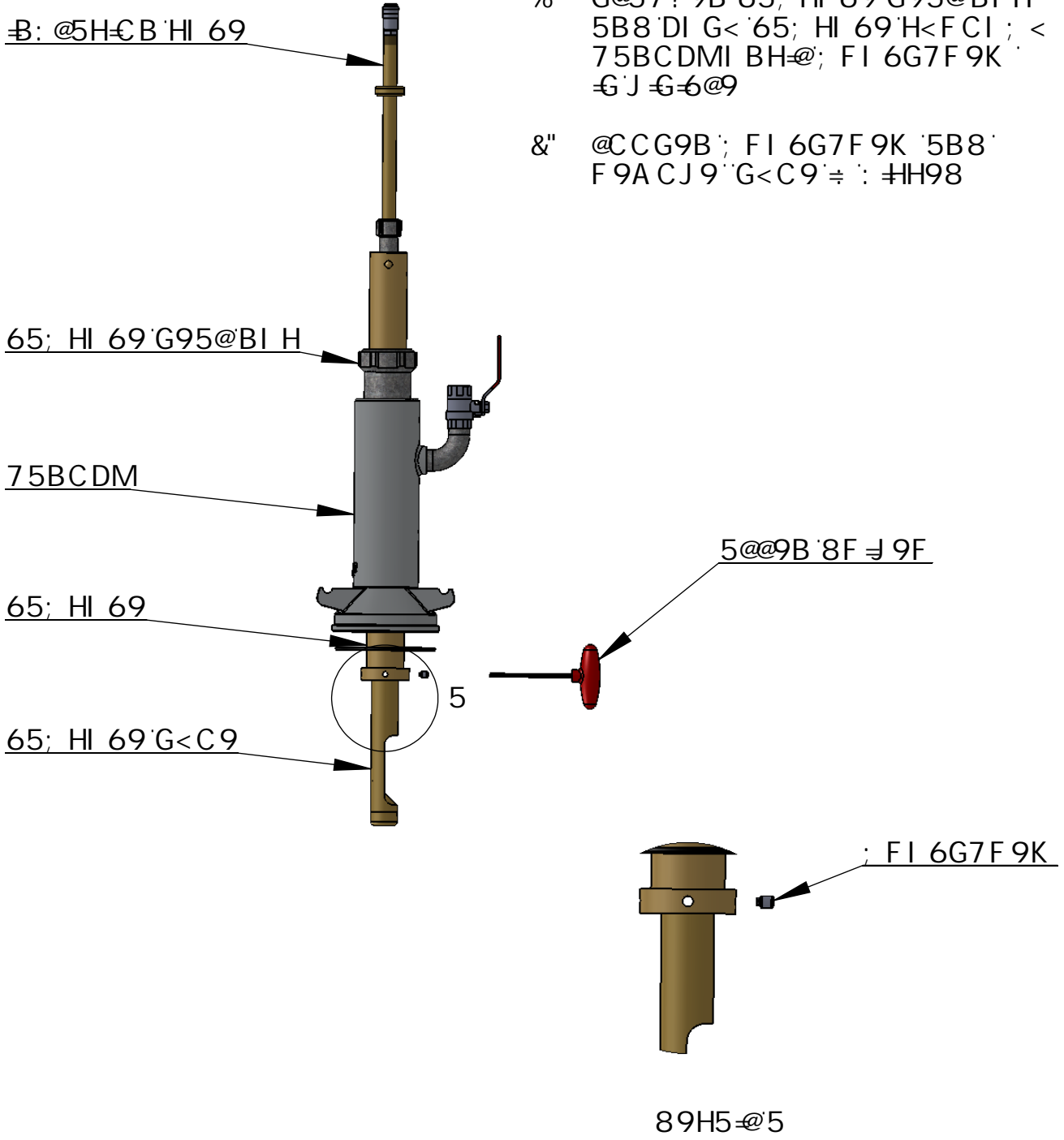

% G@57?9B 65; HI 69 G95@BI H
 5B8 DI G< 65; HI 69 H<FCI ; <
 75BCDMI BH@; FI 6G7F 9K
 €J €6@9

&" @CCG9B ; FI 6G7F 9K 5B8
 F9A CJ9 G<C9 ÷ : #H98



5@ GMGH9A G@A #H98
 %? B; 8CA 5J 9BI 9
 BCF H<57F 9 B8I GHF 5@D5F?
 K 9GH6I FMZK @HG"65% (K 9
 H9@ ÉI I A€D€H HÁI I GH
 9!A 5@ gUYg4 U\!gmYg g"Vt"i _

GH9D''

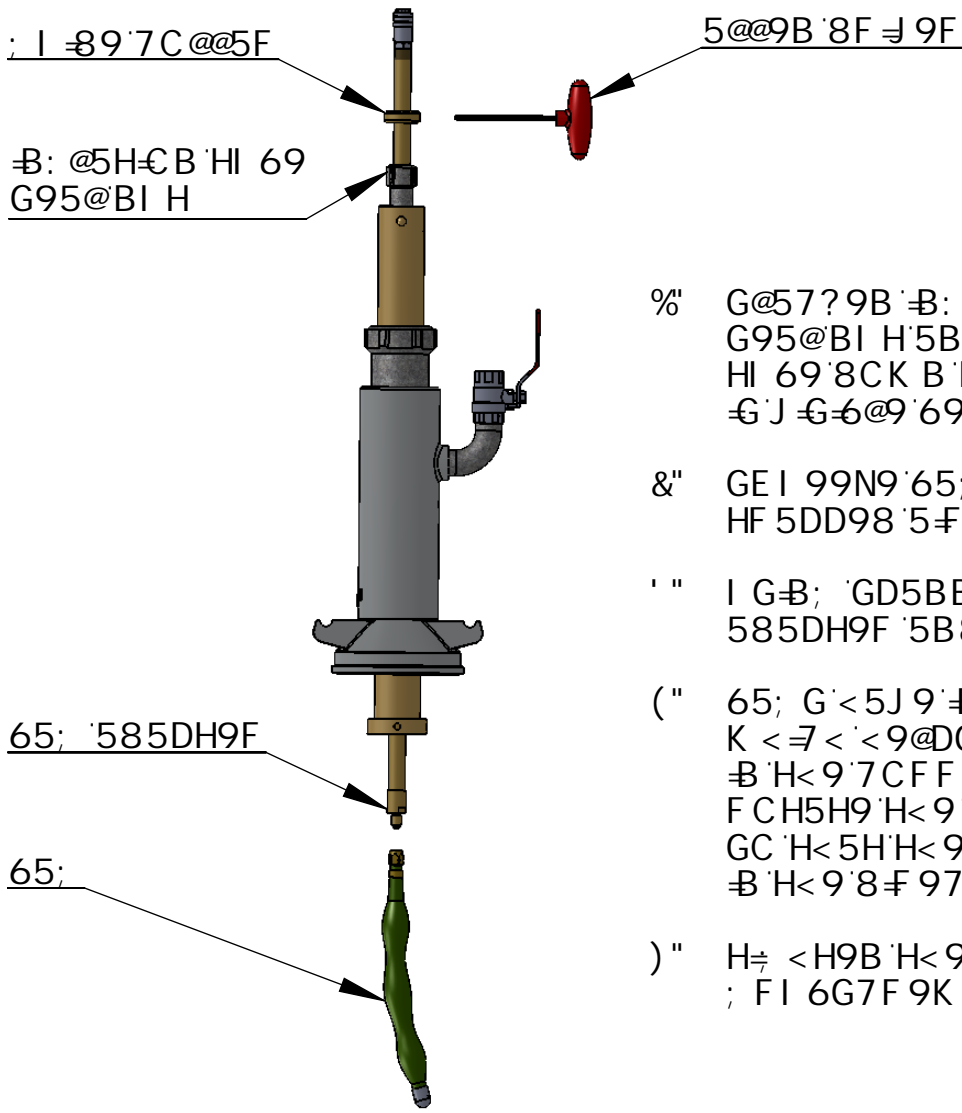

- % G@57?9B -B: @5H€B'HI 69 G95@BI H'5B8'DI G< -B: @5H€B HI 69'8CK B'I BH@65; '585DH9F €J €6@9'69@CK '65; HI 69
- &" GE I 99N9'65; 'HC F 9A CJ 9'5@@ HF 5DD98'5F
- ' " I G-B; 'GD5BB9FG<C@8'65; 585DH9F '5B8'G7F 9K 'CB'65;
- (" 65; G<5J9'-B6I €H'7I FJ 5HI F 9 K <7<'<9@DG'@5I B7<'H<9'65; -B'H<9'7CFF 97H'8F 97H€B" FCH5H9'H<9; I 89'7C@@5F GC'H<5H'H<9; FI 6G7F 9K 'DC-BHG -B'H<9'8F 97H€B'C: 'H<9'7I FJ 9"
-)" H7 <H9B'H<9; I 89'7C@@5F ; FI 6G7F 9K



5@ GMGH9A G'@A #H98
 %? -B; 8CA '5J 9BI 9
 BCF H<57F 9'-B8I GHF -5@D5F?
 K 9GH6I FMZK €HG"65% (K 9

H9@ ÉI A€DA'HI HÁIIGH

9!A 5-@ gUYg4 U\!gmYg g"Vt"i _

GH9D`(`

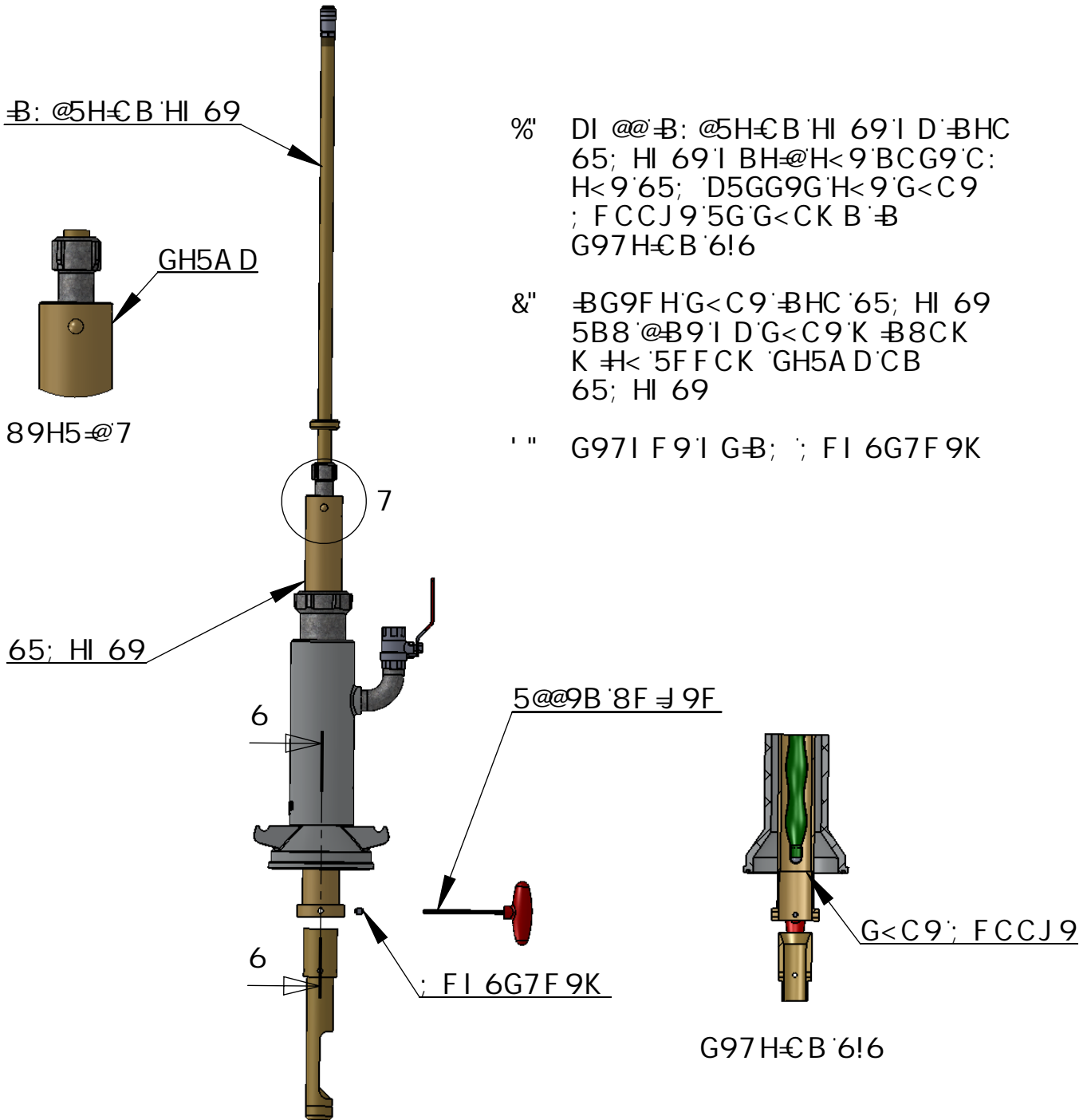

%` DI @@-B: @5H€B`HI 69`I D`-BHC
 65; HI 69`I BH@H<9`BCG9`C:
 H<9`65; `D5GG9G`H<9`G<C9
 ; FCCJ 9`5G`G<CK B`-B
 G97H€B`6!6

&` -BG9F H`G<C9`-BHC`65; HI 69
 5B8`@B9`I D`G<C9`K`-B8CK
 K`H<`5FFCK`GH5A D`CB
 65; HI 69

' "` G97I F 9`I G-B; ; FI 6G7F 9K



5@` GMGH9A G`@A`H98
 %?`-B; 8CA`5J 9BI 9
 BCF H<57F 9`-B8I`GHF`-5@D5F?
 K 9GH6I F M`K`-HG`65%` (K 9
 H9@` É I I A G D A F I H A I I G H
 9!A 5-@` gU`Yg4 U`!\!gm`Y a g`"Vt`"i`_

GH9D)

B: @5H€B'7CBHFC@
5GG9A 6@M

; I =89'7C@5F

B: @5H€B'HI 69
G95@BI H

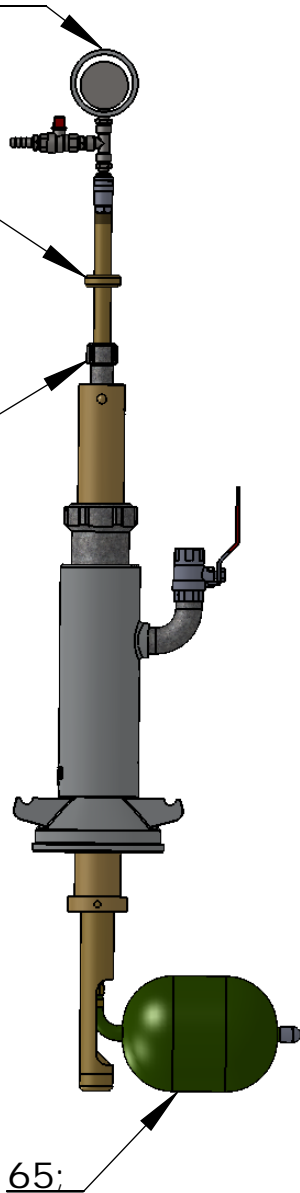

% : #'B: @5H€B'7CBHFC@5GG9A 6@M

&" 89D@CM65;

' " B: @5H9'65; 'HC'DF'9GGI'F'9; ∅'9B
69@CK'5B8'<C@8: CF')'A'BI'H9G"
8I'F'B; 'H<G'HA'9'H<9F'9'G<CI'@8'
69'N9FC'@95?5; 9

(" 7<97?'7CB8#€B'€: '65; G: CF
85A5; 9'CF: 5I'@HG

)" K #<'H<9'6CHHCA'€: 'H<9'65;
@9J'9@K #<'H<9'6CHHCA'€: 'H<9'
G<C9Ž'ACJ'9'H<9; I =89'7C@5F
GC'H<5H'#F'9GHG'>I'GH'56CJ'9
H<9'B: @5H€B'HI 69'G95@BI H

†'H<G'K @57H'5G'5; I =89'K <9B
'89D@CMB; 'H<9'65;

ÚÓÒÀÙZÒÁÏ	ÚÛÒÙÙWÜÒÁÓËÛD
'	\$"+\$
(\$"* \$
*	\$") \$
,	\$"(\$
%"	\$")
%&	\$"& ,



5@ GMGH9A G'@A #H9
%? B; 8CA '5J'9BI 9
BCFH<57F'9'B8I'GHF'5@D5F?
K'9GH6I'FM'K @HG"65% (K'9

H9@ ÉI'Á€D'FI'HÁ'Ï'GH

9!A 5=@ gUYg4 U\!gmY'a g"Vt"i _

GH9D *

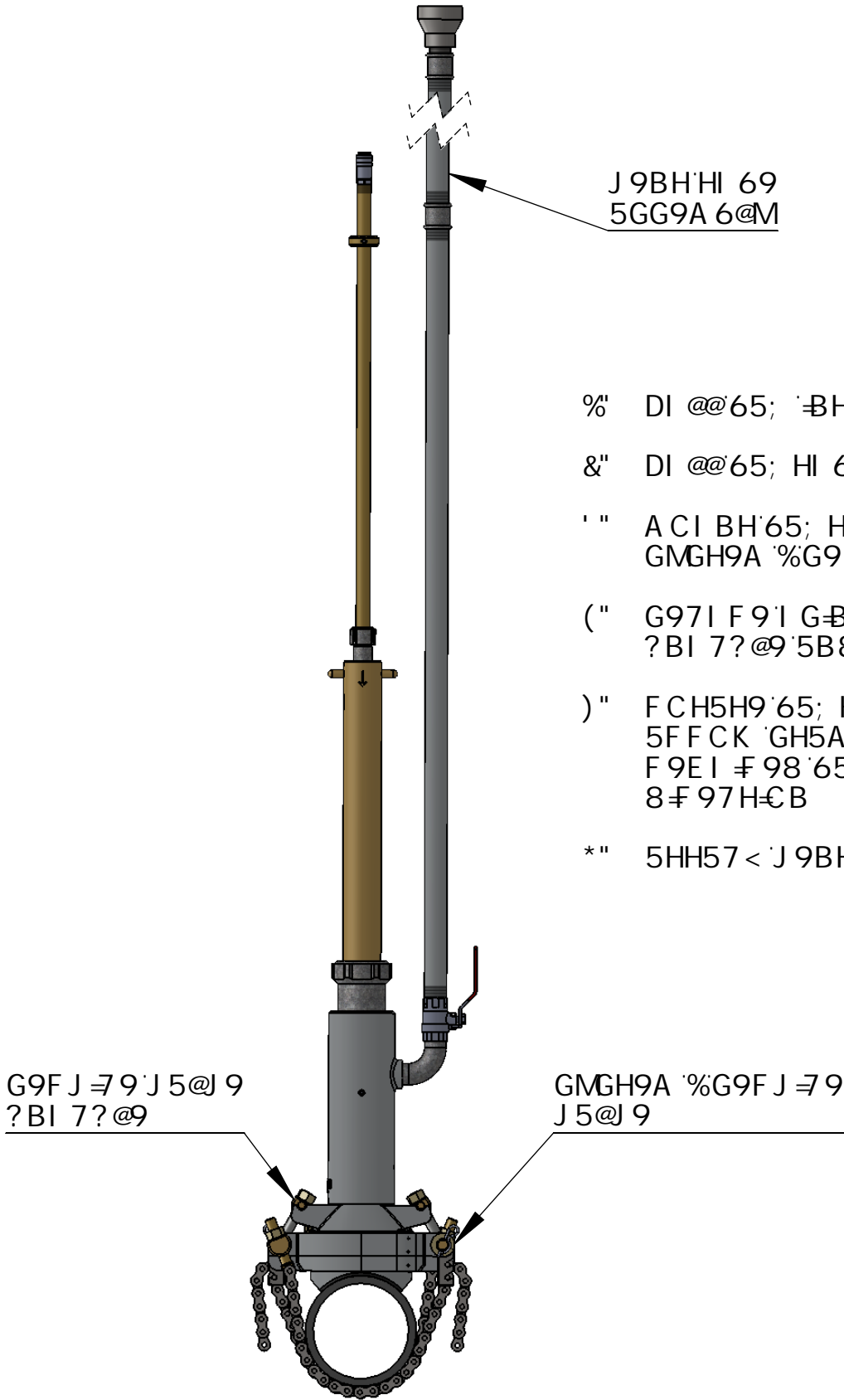

J 9BH'HI 69
5GG9A 6@M

% DI @@65; 'BHC'65; HI 69

&" DI @@65; HI 69' I D' BHC' 75BCDM

' " ACI BH'65; HI 69' 5GG9A 6@MCB'
GMGH9A '%G9F J 79' J 5@ 9

(" G97I F 9' I G'B; 'G9F J 79' J 5@ 9
'BI 7?'@9' 5B8' H7 <H9B' BI HG

)" F CH5H9'65; HI 69' GC' H<5H
5FFCK 'GH5AD' G' B@B9' K #k
F9EI #98'65; 'BG9FH€B
8#97H€B

*" 5HH57< 'J 9BH'HI 69' 5GG9A 6@M

G9F J 79' J 5@ 9
'BI 7?'@9

GMGH9A '%G9F J 79'
J 5@ 9



5@< 'GMGH9A G'@A #H98
%?' B; 8CA '5J 9BI 9
BCFH<57F 9' B8I GHF -5@D5F?
K 9GH6I FM'K -@HG''65% (K 9

H9@ É I A G D A H A I I G H

9!A 5=@ gU'Yg4 U\!gmY'a g"Vt"i _

GH9D'+

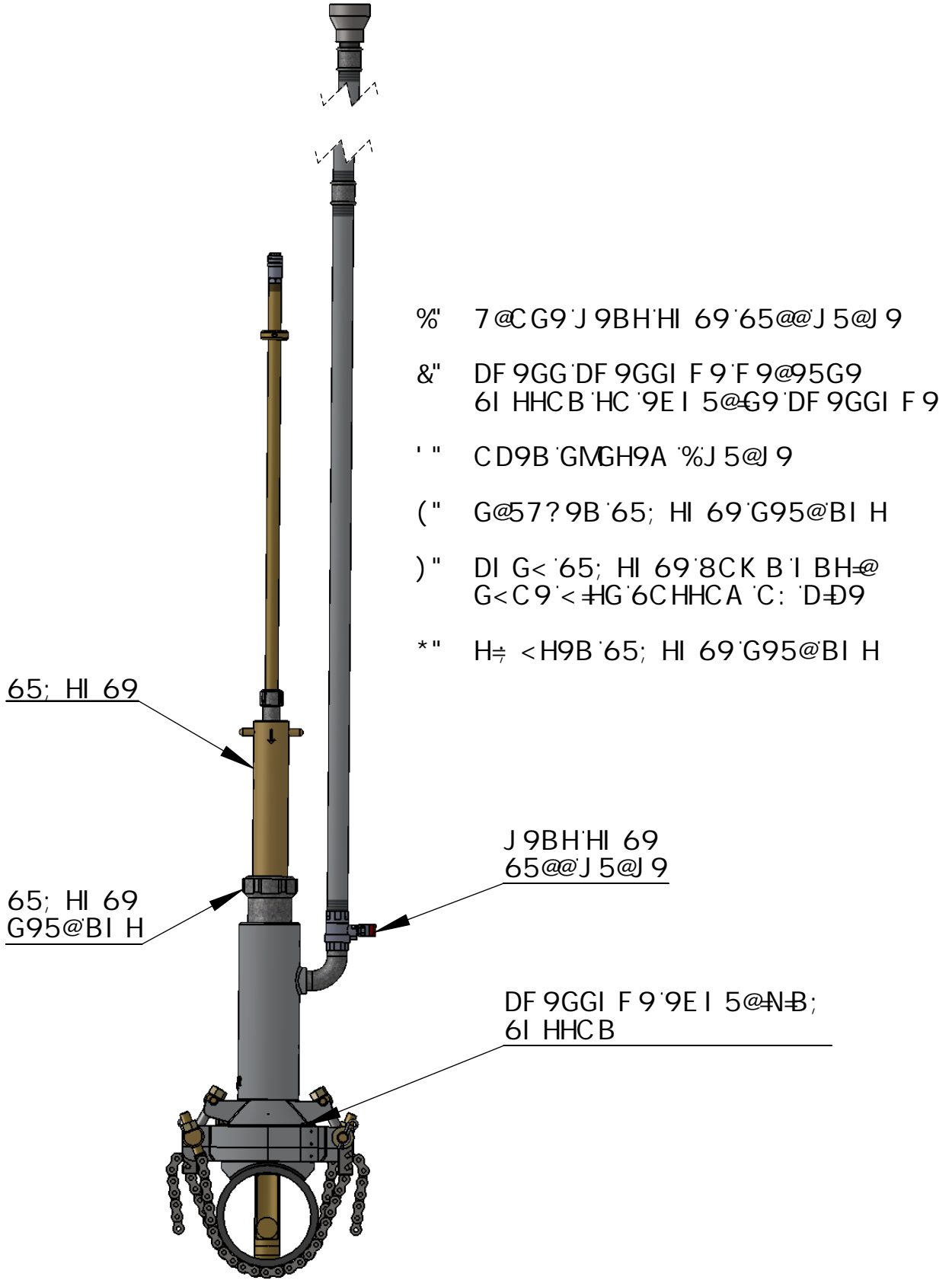

% 7@CG9'J 9BH'HI 69'65@@J 5@J 9
 & DF 9GGI F 9'9E I 5@NB; 6I HHCB
 ' " CD9B'GMGH9A '%J 5@J 9
 (" G@57?9B'65; HI 69'G95@BI H
)" DI G<'65; HI 69'8CK B I BH@G<C9'<#HG'6CHHCA 'C: 'D=9
 * " H< <H9B'65; HI 69'G95@BI H



5@ GMGH9A G'A #98
 %? #; 8CA '5J 9BI 9
 BCF H<57F 9'8BI GHF -5@D5F?
 K 9GH6I FMZK @HG"65% (K 9

H9@ É I A G D A H A I I G H
 9!A 5=@ gUYg4 U\!gmY a g"Vt"i _

GH9D'

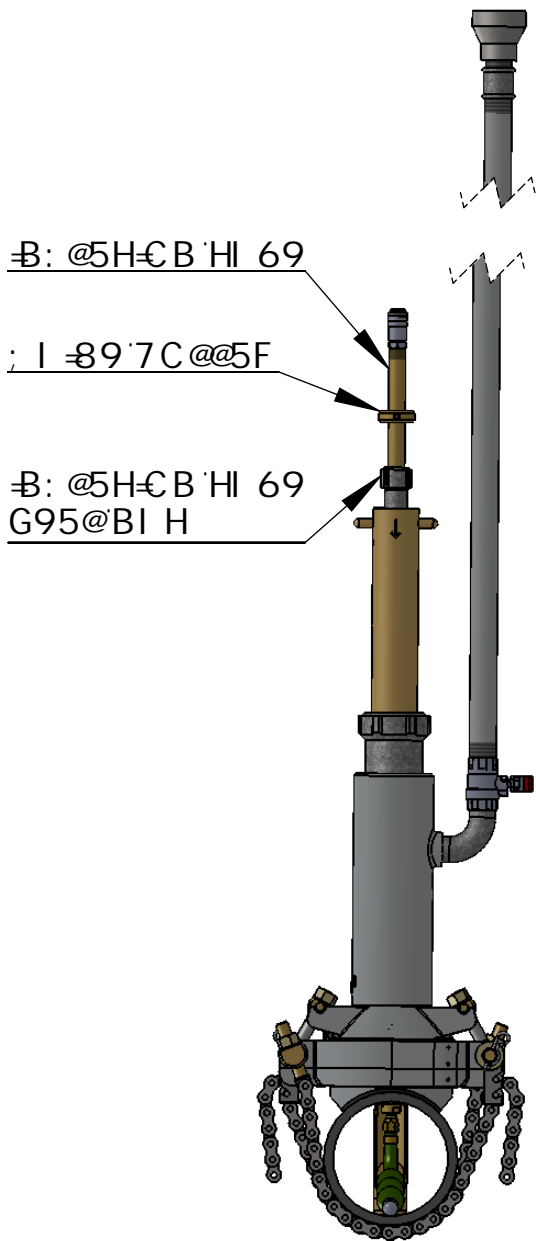

% G@57?9B' B: @5H€B'HI 69
G95@BI H

&" ; 9BH@MDI G< 'B: @5H€B'
HI 69'8CK B'I BH@; I 89
7C@@5F 'G> GH'56CJ 9
B: @5H€B'HI 69'G95@
BI H



5@ GMGH9A G'A #H98
%? B; 8CA '5J 9BI 9
BCFH<57F 9' B8I GHF -5@D5F?
K 9GH6I FMZK @HG"65% (K 9

H9@ ÉI I A G D A H A I I G H

9!A 5=@ gUYg4 U\!gmYg g"Vt"i _

B: @5H€B 'G9E I 9B79 '5B8 'G9D5F 5H€B
8€GH5B79

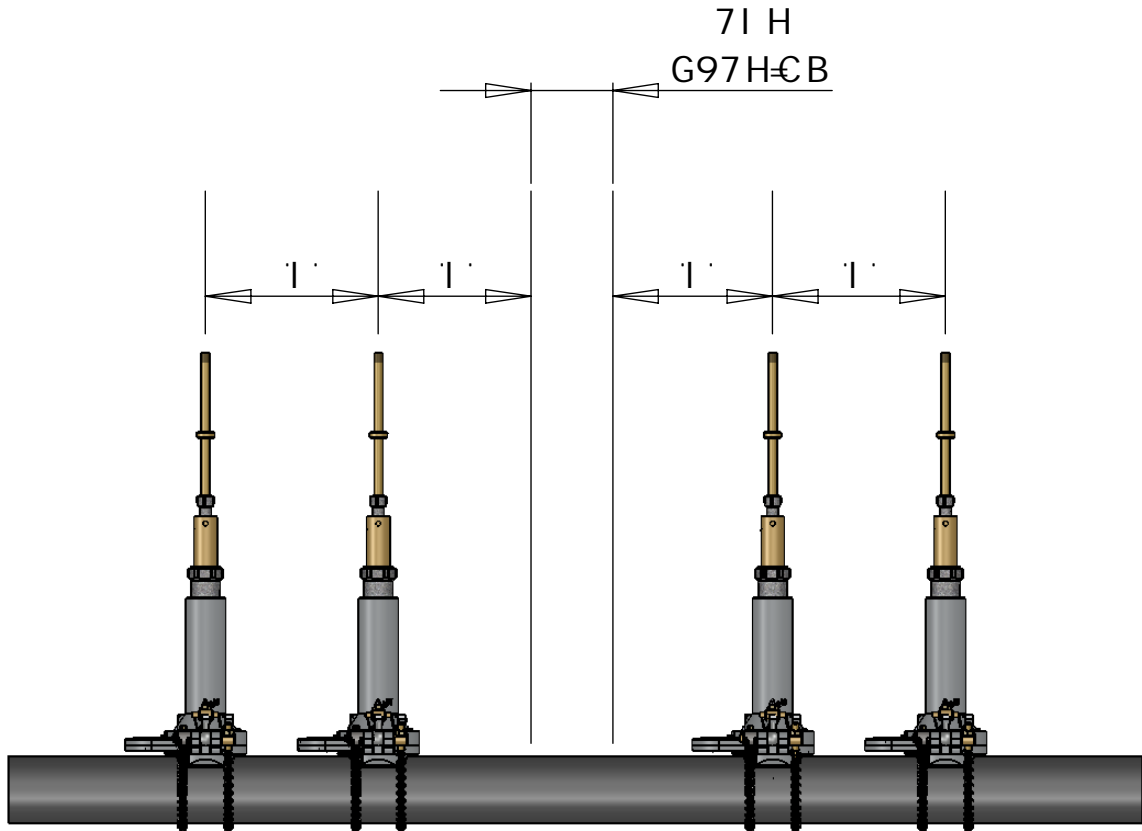

B: @5H€B
G9E I 9B79

(

&

← : @CK

%

'

D€D9 'G€N9	8 A 9BG€CB 'fi fi A B'
' "	')\$'a a
("	')\$'a a
* "	')\$'a a
,	(\$\$'a a
%' "	()\$'a a
%' ") \$\$'a a



5@€ 'GMGH9A G'€A #H98
%? B; 8CA '5J 9BI 9
BCFH<57F9'€B8I GHF -5@D5F?
K 9GH6I FM€K €HG''65% (K 9

H9@ €I I A€D€H H€I I G€H

9!A 5-@ gUYg4 U\!gmY€a g"V€"i _